

Worked example

Apportioning the use of losses – new eligible tier-1 company joins part-way through income year

Description This example shows how a group apportions use of its unutilised prior year losses if a new eligible tier-1 company joins the group part-way through the group's income year.

Note

For more information about:

- loss bundles and calculating the available fraction → 'Treatment of losses', C3-1; 'Consolidation loss provisions', C3-2-110 (worked example)
- adjustments to available fractions → 'Adjusting available fraction – eligible tier-1 company joins MEC group', C10-2-310 (worked example)
- apportioning the use of transferred losses → C3-4-610 (worked example)

Commentary The apportionment rule in section 707-335 applies when the numerical value of an available fraction for a bundle of losses changes during an income year. The apportionment rule ensures an adjusted available fraction only applies from the date it is reset.

Existing available fractions are reset when a new eligible tier-1 company (→ section 719-15) joins a group. Also, any prior year losses generated by the group (group losses) before the eligible tier-1 company joins are treated as transferred losses from the joining time. Apportionment applies (assuming losses can be utilised) if the new eligible tier-1 company joins part-way through the group's income year.

In the income year the eligible tier-1 company joins, apportionment applies to both transferred losses and group losses. The use of group losses for the pre-joining period is unrestricted. This is achieved by treating the group losses as being in a bundle with an available fraction of 1 for the pre-joining period. The use of group losses for the post-joining period is subject to the available fraction established for their bundle.

The available fraction of 1 that is assigned to the group loss bundle is *not* reset if an adjustment would be required in relation to an event occurring during the pre-joining period. This is consistent with the losses maintaining their group loss status for the pre-joining period.

The amount of a group loss that can be used with reference to the pre-joining period is taken *not* to have been a loss transferred under Subdivision 707-A. The status of the group loss remains and hence the amount attributable to the pre-joining period must be deducted from the group's income and gains before applying the available fraction when determining the limits on utilisation of other transferred losses. Once a new eligible tier-1 company joins the group, the status of the group loss changes to a transferred loss. Hence the amount attributable to the post-joining period is *not* deducted from the group's income or gains when determining the limits on utilisation of other transferred losses under the available fraction method.

Example

Facts MEC1 Group consists of a provisional head company, PHC, an eligible tier-1 company, BCo, and another company, ACo. A loss made by ACo is transferred to PHC when ACo joins the group. An available fraction of 0.223 is established for bundle ACo at the initial transfer time. MEC1 Group also incurs a group loss in the 2003 income year.

On 1 October 2003 the group's market value is increased as a result of a non-arm's length (NAL) transaction involving MEC1 Group and its top company, TC. The market value of the group just before the event is \$1,000. The non-arm's length transaction has the effect of increasing the group's market value by \$150.

On 1 January 2004, TC acquires an eligible tier-1 company, ET-1 and a choice is made for ET-1 to join MEC1 Group. → subsection 719-5(4)

This sequence of events is shown in figures 1 and 2.

Figure 1: TC acquires ET-1

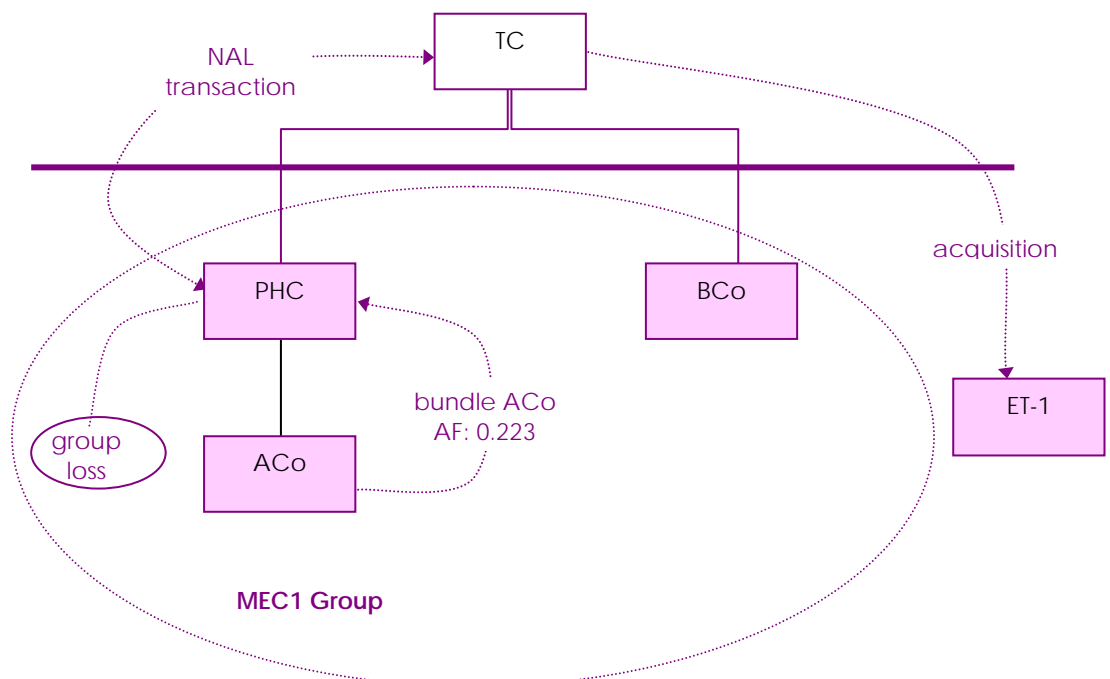
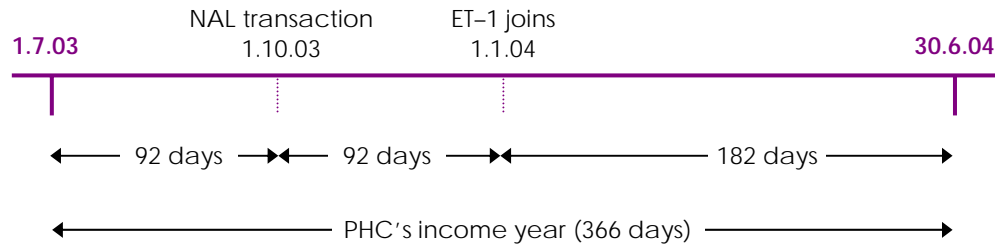

Figure 2: The 2004 income year



As a result of the non-arm's length transaction, MEC1 Group must adjust the available fraction for bundle ACo under item 4 in the table in subsection 707-320(2). MEC1 Group must also establish an available fraction for the prior year group loss and adjust the available fraction for bundle ACo in recognition of the entry of ET-1.

Market values were ascertained as at the time of ET-1 joining (1 January 2004) as follows:

- market value of MEC1 Group (excluding market value of ET-1) = \$1,150
- market value of MEC1 Group (including market value of ET-1) = \$1,600
- modified market value¹ of PHC (as the real loss-maker) = \$820
- adjusted market value² of PHC (as the transferee) = \$1,420

Losses available for utilisation in the 2004 income year are shown in table 1.

Table 1: Losses available in 2004 income year

Loss bundle	Unused transferred losses
Group loss	\$480 tax loss (not film)
Bundle ACo	\$120 tax loss (not film)

PHC satisfies the recoupment tests for utilisation of both the group loss and the transferred loss in the 2004 income year.

PHC generates \$975 of assessable income. Its deductions in relation to that income are \$178.

¹ Section 707-325. Modified market value is the market value reduced by the value of the NAL transaction (\$150) and assuming the group had no losses. The value of losses in this example is assumed to be the quantum of the losses multiplied by the prevailing corporate tax rate (\$600 x 0.30 = \$180).

² Subsection 707-320(1). Adjusted market value is the value of the expanded group ignoring any losses it has and assuming that its franking account balance is nil.

Calculation –
available
fractions

Step 1 – Apply adjustment item 4 to the available fraction for bundle ACo (as at 1 October 2003) by multiplying each by the item 4 factor:

$$0.223 \quad \times \quad \frac{1,000}{1,000 + 150} = 0.194$$

Step 2 – Establish an available fraction (as at 1 January 2004) for the group loss (bundle GL):

$$\frac{820}{1,420} = 0.577$$

Step 3 – Adjust the available fraction for bundle ACo (as at 1 January 2004) by multiplying it by the market value factor³:

$$0.194 \quad \times \quad \frac{1,150}{1,600} = 0.139$$

The sum of available fractions for bundles GL and ACo is 0.716 (0.577 + 0.139). This figure will be the denominator of the capping adjustment factor.

Step 4 – Cap the available fractions for bundles GL and ACo by multiplying each by the capping adjustment factor⁴:

$$\text{GL:} \quad 0.577 \quad \times \quad \frac{0.577}{0.716} = 0.465$$

$$\text{ACo:} \quad 0.139 \quad \times \quad \frac{0.577}{0.716} = 0.112$$

The sum of available fractions for bundles GL and ACo is 0.577 (0.465 + 0.112). This corresponds with the available fraction initially calculated for bundle GL.

The utilisation of losses for the 2004 income year is subject to limits determined by reference to the available fraction method.

³ Market value of the original group divided by market value of the expanded group.

⁴ The group may avoid the application of step 3 by choosing to cancel the loss in bundle GL. Broadly, the effect of cancellation is that the cancelled loss could be used up until ET-1 joins but cannot be used thereafter. The choice to cancel a loss is contained in section 719-325. The choice to cancel a loss may be revoked where the revocation takes place before 1 January 2006.

Calculation –
utilisation

A. Work out the amount of loss from bundle GL that can be utilised with reference to the pre-joining period.

Table 2: Categories of group income or gains (bundle GL utilisation)

Category of income or gains	Gross amount (\$)	Less: other allowable deductions/reductions (\$)	Less: group/concessional losses of that kind(\$)	Income/gains available for the bundle (\$)
Other assessable income	975	178	–	797

Table 3 Fraction of income/gains (bundle GL utilisation)

Category of income or gains	Loss bundle	Step 1 amount	Multiplied by: available fraction (AF)	Multiplied by: apportionment fraction	AF amount for the bundle
Other assessable income	Bundle GL	\$797	1.000	184/366	\$401

B. Apply the 3-step available fraction method to each bundle

Step 1 – Work out the categories of group income or gains – subsection 707-310(3)

Table 4: Categories of group income or gains (bundle ACo utilisation) (step 1)

Category of income or gains	Gross amount (\$)	Less: other allowable deductions/reductions (\$)	Less: group/concessional losses of that kind(\$)	Income/gains available for the bundle (\$)
Other assessable income	975	178	401	396

Step 2 – Calculate the fraction of the income/gains that is attributable to each bundle – subsection 707-310(3)

Table 5: Fraction of income/gains attributable to each bundle (step 2)

Category of income or gains	Loss bundle	Step 1 amount	Multiplied by: available fraction (AF)	Multiplied by: apportionment fraction	AF amount for the bundle	
Other assessable income	Bundle GL	\$797	1.000	184/366	\$401	} \$585
		\$797	0.465	182/366	\$184	
	Bundle ACo	\$396	0.223	92/366	\$22	} \$63
\$396		0.194	92/366	\$19		
\$396		0.112	182/366	\$22		

Note: Bundle GL loss utilised with reference to the pre-joining period is not subtracted from income when determining the post-joining period utilisation amount for that bundle.

Step 3(a) – Work out a notional taxable income for bundle GL – subsection 707-310(2)

Table 6: Taxable income (step 3a)

Assessable income	\$	Deductions/losses	\$
Other assessable income	585	Group/transferred tax loss	480
Total	585	Total	480

The (notional) taxable income for bundle GL is \$105 (\$585 – \$480).

The entire unutilised loss of \$480 in bundle GL can be used by PHC when it determines its actual taxable income for the 2004 income year.

Step 3(b) – Work out a notional taxable income for bundle ACo – subsection 707-310(2)

Table 7: Taxable income (step 3b)

Assessable income	\$	Deductions/losses	\$
Other assessable income	63	Transferred tax loss	63
Total	63	Total	63

The (notional) taxable income for bundle ACo is \$0 (\$63 – \$63).

\$63 of the loss in bundle ACo can be used by PHC when it determines its actual taxable income for the 2004 income year.

C. Determine the group's actual taxable income

Table 8: Taxable income

Assessable income	\$	Deductions/losses	\$
Other assessable income	975	Deductions	178
		Group/transferred tax losses (bundle GL)	480
		Transferred tax losses (bundle ACo)	63
Total	975	Total	721

The group's taxable income is \$254 (\$975 – \$721).

As at the start of the 2005 income year PHC will hold the bundle shown in table 9.

Table 9: PHC bundle held at start of 2005 income year

Bundle	Loss	Available fraction	Sort
ACo	\$57 (\$120 – \$63)	0.112	Tax loss (not film)

Bundle GL ceases to exist as the loss contained in it is fully utilised in the 2004 income year.

References

Income Tax Assessment Act 1997, sections 707-310, 707-320, 707-325, 707-335; as amended by *New Business Tax System (Consolidation) Act (No. 1) 2002* (No. 68 of 2002), Schedule 1

Income Tax Assessment Act 1997, Subdivision 719-F; as amended by *New Business Tax System (Consolidation and Other Measures) Act (No. 1) 2002* (No. 117 of 2002), Schedule 8

Income Tax Assessment Act 1997, paragraph 707-335(3)(e); as amended by *New Business Tax System (Consolidation and Other Measures) Act (No. 1) 2002* (No. 117 of 2002), Schedule 6, Part 2 ('Utilising losses head company transfers to itself')

Income Tax (Transitional Provisions) Act 1997, Subdivision 719-F; as amended by *New Business Tax System (Consolidation and Other Measures) Act (No. 1) 2002* (No. 117 of 2002), Schedule 10

Income Tax (Transitional Provisions) Act 1997, Subdivision 707-C; as amended by *Tax Laws Amendment (2005 Measures No. 5) Act 2005* (162 of 2005), Schedule 3, Part 2

Explanatory Memorandum to the New Business Tax System (Consolidation and Other Measures) Bill (No. 1) 2002, Chapter 3

Revision history

Section C10-2-320 first published 2 December 2002 and updated 28 May 2003.

Further revisions are described below.

Date	Amendment	Reason
26.10.05	Government announces extension of time for head companies to make or revoke certain elections.	Proposed legislative amendment.
12.9.06	Extension of time to revoke election to cancel a loss, footnote 4.	Legislative amendment.
15.4.10	Changes to Calculation – utilisation	To reflect correct application of law.

Proposed changes to consolidation

Proposed changes to consolidation announced by the Government are not incorporated into the *Consolidation reference manual* until they become law. In the interim, information about such changes can be viewed at:

- <http://assistant.treasurer.gov.au> (Assistant Treasurer's press releases)
- www.treasury.gov.au (Treasury papers on refinements to the consolidation regime).