

## Worked example

## Assumptions about the test company failing the COT – potential MEC group ceases to exist<sup>1</sup>

**Description** This example outlines a case in which the test company is deemed to have failed the continuity of ownership test (COT) because the potential MEC group ceases to exist. → 'MEC groups and losses – determining whether the focal company satisfies the continuity of ownership test', C10-2-325

**Commentary** In recognition of the special characteristics of MEC groups, Subdivision 719-F of the *Income Tax Assessment Act 1997* (ITAA 1997) modifies the rules about transferring and utilising losses within those groups.

The focal company (the company seeking to utilise the loss) is considered to have met the continuity of ownership conditions in section 165-12 of the ITAA 1997 if the test company would have met those conditions based on the assumptions in sections 719-270, 719-275 and 719-280.<sup>2</sup>

Under section 719-280, the test company is deemed to have failed the COT (section 165-12) in relation to a loss in certain circumstances. Broadly, those circumstances are where one of the following events happens to the focal company's MEC group, or potential MEC group, after the start of the focal company's ownership test period for the loss:

- the potential MEC group ceases to exist
- the potential MEC group continues to exist but the identity of the top company changes as a result of the acquisition of membership interests in certain entities below the group's original top company (the relevant entities are the group's eligible tier-1 companies or any entities interposed between the eligible tier-1 companies and the original top company), or
- there ceases to be a provisional head company for the group.

<sup>1</sup> This worked example is not applicable where the MEC group converted to a consolidated group:

- on or after 27 October 2006, or
- where the conversion to a consolidated group took place before 27 October 2006 and a choice in writing is made within the prescribed time for Subdivision 719-BA to apply from 1 July 2002.

→ section 719-140, item 17 of *Tax Laws Amendment (2010 Measures No.1) Act 2010*; paragraphs 5.92, 5.105 and 5.106 of the Explanatory Memorandum to Tax Laws Amendment (2010 Measures No.1) Bill 2010

<sup>2</sup> The assumptions contained in sections 719-270 and 719-275 relate to determining whether the test company has satisfied the COT. If the conditions in section 719-280 are satisfied, however, the test company is deemed to have failed the COT.

---

The test company will also fail the conditions in section 165-12 where those conditions are not met based on the assumptions in section 719-270 and section 719-275. Where this actual COT failure occurs in addition to a deemed COT failure (under section 719-280), the COT failure time will be the earlier of the two. Under section 719-260, the focal company is considered to have failed to meet a condition in section 165-12 only at the first time that the test company would have failed to meet the condition.

## Example

**Facts** A wholly-owned group of entities comprising TopCo, HCo, SubCoA, SubCoB, FRCo and ET1Co exists throughout the income year ended 30 June 2003. TopCo is a foreign-resident company that owns all of the membership interests in FRCo (another foreign-resident company) and HCo (an Australian-resident company). In turn, FRCo owns all the membership interests in ET1Co (an Australian-resident company). HCo owns all of the membership interests in the Australian-resident companies SubCoA and SubCoB.

As shown in figure 1, a MEC group forms on 1 July 2003, consisting of SubCoA, SubCoB and the eligible tier-1 companies HCo and ET1Co. HCo is nominated as the provisional head company. On that date, Rod holds 72% of the membership interests in TopCo and Ray holds the remaining membership interests. These membership interests are held continuously from 1 July 2002 to 30 June 2006.

At formation, a loss made by ET1Co for the income year ended 30 June 2003 is transferred to HCo as a COT transfer. HCo is the head company of the MEC group for the income year in which the loss is transferred as it is the provisional head company at the end of that income year. → section 719-75

On 9 October 2003, XCo, an Australian-resident company, acquires all of the membership interests in FRCo (figure 2). As ET1Co is then no longer a wholly-owned subsidiary of the top company, TopCo,<sup>3</sup> it ceases to be a member of the MEC group.

On 1 September 2004, Jenny acquires 5% of the membership interests in HCo. Consequently, HCo ceases to be an eligible tier-1 company<sup>4</sup> and the potential MEC group consisting of HCo, SubCoA and SubCoB ceases to exist.<sup>5</sup> However, the conditions in section 703-55 are satisfied<sup>6</sup> and as such, a

---

<sup>3</sup> A requirement for being a tier-1 company (and thus an eligible tier-1 company) is that the company must be a wholly-owned subsidiary of the top company: see item 2 in the table in subsection 719-20(1).

<sup>4</sup> HCo ceases to be an eligible tier-1 company because it ceases to be a wholly-owned subsidiary of the top company.

<sup>5</sup> The potential MEC group ceases to exist because there are no longer any eligible tier-1 companies: see paragraph 719-10(7)(a).

consolidated group is created from the MEC group. The consolidated group will consist of HCo, as the head company, and SubCoA and SubCoB as subsidiary members.

HCo, now the head company of a consolidated group, seeks to utilise the transferred COT loss in the income year ended 30 June 2006.

Figure 1: MEC group as at 1 July 2003 (formation time)

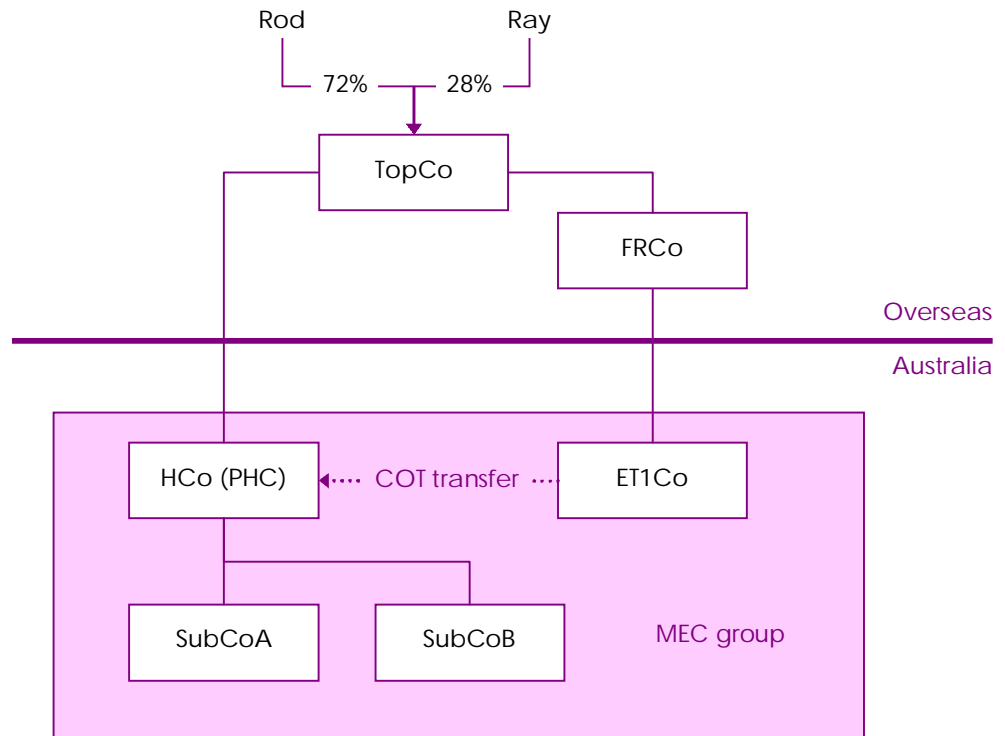

<sup>6</sup> Section 703-55 is satisfied as the MEC group ceased to exist because HCo, the sole eligible tier-1 company of the MEC group, ceased being an eligible tier-1 company and immediately after this time met the conditions for being a head company of a consolidated group (in section 703-15).

Figure 2: Post-formation changes in membership interests

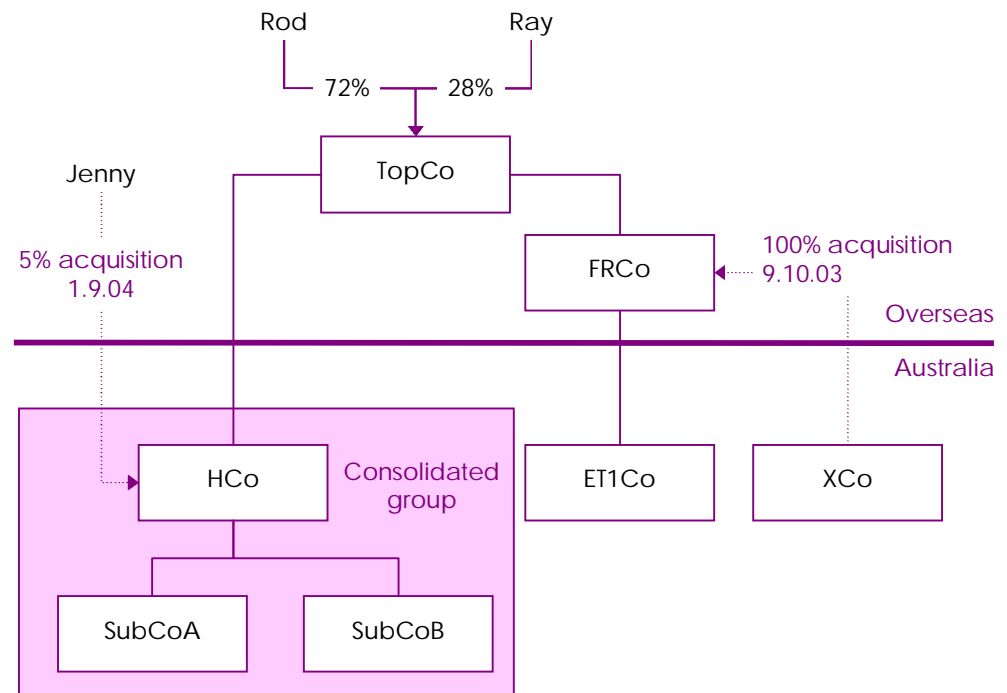

**Calculation** HCo, the focal company, will be considered to have satisfied the continuity of ownership conditions in section 165-12 if the test company would have met those conditions based on the assumptions in sections 719-270, 719-275 and 719-280. In addition to establishing whether there has been a deemed COT failure under section 719-280 (step 5 below), it is also necessary to determine whether the COT has been satisfied in relation to the assumptions set out in sections 719-270 and 719-275 (steps 1 to 4 below).

*Step 1: Identify the test company*

Applying section 719-265, the test company is ET1Co.

Item 2 in the table in subsection 719-265(2) applies because the loss is a transferred COT loss and HCo (the focal company) and ET1Co (the transferor) are different entities. On a re-application of the rules in section 719-265 (as required by paragraph 719-265(1)(b)), item 3 in the table in subsection 719-265(4) applies to determine that ET1Co is the test company.

*Step 2: Assume that the test company made the loss*

Applying section 719-270, ET1Co is considered to have made the loss.

Subsection 719-270(4) applies as neither subsection 719-270(1) or (2) applies. That is, ET1Co (the test company) was not the top company for HCo's (the focal company's) MEC group. Also, it was not the focal company or the first head company.

---

*Step 3: Identify the start of the income year for which the test company is taken to have made the loss*

Applying section 719-270, ET1Co (the test company) is taken to have made the loss in an income year starting on 1 July 2002.

Item 1 in the table in subsection 719-270(4) applies because ET1Co is the original loss-maker. Under this item, the start of the test company's loss year is the start of the income year in which it made the loss (in this case, 1 July 2002).

*Step 4: Apply the COT to the test company, ignoring ownership and voting changes below the top company*

Applying section 719-275, the ownership structure between TopCo and ET1Co is considered 'frozen' from 1 July 2003, when the loss was transferred to HCo, the head company of the MEC group. Changes in the membership interests in ET1Co and FRCo after this event are ignored for the purposes of determining whether the continuity of ownership conditions in section 165-12 are met. This includes the acquisition of FRCo's interests by XCo on 9 October 2003.

Note that item 1 in subsection 719-275(2) applies because there was a COT transfer of a loss (made by ET1Co) to HCo (the head company of the MEC group) within the period beginning 1 July 2002 (the start of the income year in which ET1Co is taken to have made the loss under section 719-270) and ending 30 June 2006 (the end of the loss claim year).

Taking into account the assumptions in sections 719-270 and 719-275, the test company, ET1Co, passes the COT. It satisfies the conditions in section 165-12 because 100% of ET1Co's ultimate ownership remains unchanged from the start of its loss year (1 July 2002) to the time that the loss is transferred to HCo as a COT transfer. Further, after the transfer time and until the end of the loss claim year (30 June 2006), 100% of TopCo's ownership remains constant.

However, ET1Co will fail to satisfy the conditions in section 165-12 if the deemed COT failure in section 719-280 applies.

*Step 5: Determine whether the deemed COT failure applies*

Section 719-280 applies to deem the test company, ET1Co, to have failed the continuity of ownership conditions in section 165-12 because a specified 'failing' event in subsection 719-280(2) occurs on 1 September 2004, which is after the start of HCo's (the focal company's) ownership test period (1 July 2003<sup>7</sup>). The specified 'failing' event in this instance is the cessation of the potential MEC group, which occurs on 1 September 2004 as a result of Jenny acquiring 5% of the shares in HCo.

---

<sup>7</sup> As the focal company, HCo, made the loss because of a transfer under Subdivision 707-A, section 707-205 has the effect that the ownership test period for HCo starts at the time of the transfer (i.e 1 July 2003).

*Step 6: Determine whether the focal company meets the conditions in section 165-12*

Under subsection 719-260(1), the focal company is considered to meet the continuity of ownership conditions in section 165-12 if the test company meets those conditions (based on the relevant assumptions).

In this case, therefore, the focal company, HCo, does not meet the conditions in section 165-12 because the test company, ET1Co, does not meet those conditions based on all the assumptions in sections 719-270, 719-275 and 719-280. In particular, ET1Co fails to meet the conditions in section 719-280.

HCo is considered to have failed the conditions in section 165-12 on 1 September 2004, at the time that ET1Co is deemed to have failed them based on the assumptions in section 719-280.

## References

*Income Tax Assessment Act 1997:*

- section 165-12
- subdivision 719-A
- section 719-140; as inserted by *Tax Laws Amendment (2010 Measures No.1) Act 2010* (No. 56 of 2010), Schedule 5, Part 2

Explanatory Memorandum to the New Business Tax System (Consolidation) Bill (No. 1) 2002, Chapter 4

*Income Tax Assessment Act 1997*, Subdivision 719-F; as amended by *New Business Tax System (Consolidation and Other Measures) Act 2003* (No. 16 of 2003), Schedule 13

Explanatory Memorandum to the New Business Tax System (Consolidation and Other Measures) Bill (No. 2) 2002, Chapter 3

*Tax Laws Amendment (2010 Measures No.1) Act 2010*, item 17

Explanatory Memorandum to Tax Laws Amendment (2010 Measures No.1) Bill 2010, paragraphs 5.92, 5.105 and 5.106

Revision history

Section C10-2-391 first published 2 October 2003.

Further revisions are described below.

| Date   | Application  | Reason                 |
|--------|--|------------------------|
| 6.5.11 | Addition of footnote p. 1 to reflect changes to the group conversion provisions. | Legislative amendment. |