

Worked example

Identifying the test company to determine continuity of ownership of the focal company in a MEC group (SBT satisfied)

Description This example shows how the test company is identified when a loss is transferred to the head company of a MEC group because the same business test (SBT) is satisfied. → 'MEC groups and losses – determining whether the focal company satisfies the continuity of ownership test', C10-2-325 (high-level worked example)

Commentary In recognition of the special characteristics of MEC groups, Subdivision 719-F of the *Income Tax Assessment Act 1997* (ITAA 1997) modifies the rules about transferring and utilising losses within those groups.

The head company of a MEC group that is seeking to utilise a loss transferred to it from another company in the group is known as the focal company. It is considered to have satisfied the continuity of ownership test (COT) if the company defined as the test company satisfies that test. The tables in section 719-265 are used to identify the test company based on how the focal company made the loss. Subsection 719-265(3) applies when the loss is transferred to the focal company under Subdivision 707-A because the same business test is satisfied.

Example

Facts A MEC group consisting of ECo and HCo forms on 1 July 2002. On 30 September 2002, ECo acquires 100% of the share capital of SubCo. HCo, as head company of the MEC group, notifies the Commissioner that SubCo has become a member of the MEC group.

A tax loss made by SubCo in the year ended 30 June 2000 is transferred to HCo under Subdivision 707-A because the same business test is satisfied.

The focal company, HCo, seeks to claim a deduction for the tax loss transferred to it. At all times since the MEC group formed, HCo has been the head company and TopCo has been the top company.

The structure of the MEC group is shown in figure 1.

Figure 1: Structure of the MEC group

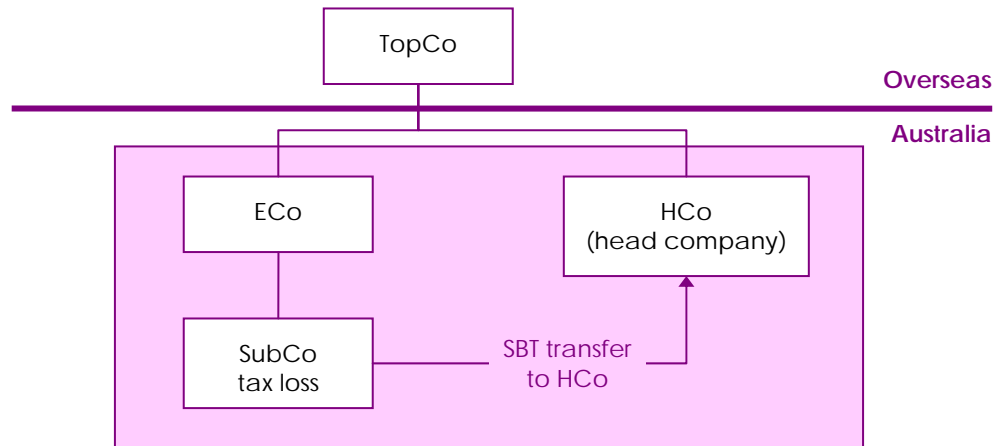

Calculation The table in subsection 719-265(3) applies as the loss was transferred to HCo from SubCo under Subdivision 707-A because the same business test was satisfied.

Item 1 in the table applies as the focal company, HCo, was the head company of the MEC group at the time of the transfer on 30 September 2002.

Column 2 of item 1 in the table states that the test company is the top company of the MEC group at the time of the transfer. In this case, the test company is therefore TopCo which has been the top company at all times since the MEC group formed on 1 July 2002.

References *Income Tax Assessment Act 1997*, section 165-12

Income Tax Assessment Act 1997, Subdivision 719-F; as amended by *New Business Tax System (Consolidation and Other Measures) Act 2003* (No. 16 of 2003), Schedule 13

Explanatory Memorandum to the *New Business Tax System (Consolidation and Other Measures) Bill (No. 2) 2002*, Chapter 3

Income Tax Assessment Act 1997, Subdivision 707-A; as amended by *New Business Tax System (Consolidation) Act (No. 1) 2002* (No. 68 of 2002), Schedule 1