

## Worked example

## Determining the start of a test company's loss year to assess the continuity of ownership of the focal company in a MEC group (COT transfer of a loss)

**Description** This example shows how to determine the start of the test company's loss year when a loss is transferred to the head company of a MEC group as a continuity of ownership test (COT) transfer from another company. This is part of the process of assessing the continuity of ownership of the group's focal company (the company that seeks to utilise the loss). → 'MEC groups and losses – determining whether the focal company satisfies the continuity of ownership test', C10-2-325

**Commentary** In recognition of the special characteristics of MEC groups, Subdivision 719-F of the *Income Tax Assessment Act 1997* (ITAA 1997) modifies the rules about transferring and utilising losses within those groups.<sup>1</sup>

In order to apply the COT to the test company, it is necessary to assume that the test company made the loss, even if it actually did not (e.g. because the test company is also the top company).

The COT is applied to the test company for its ownership test period – the period from the start of the test company's loss year until the end of the income year in which the focal company seeks to utilise the loss.

The tables in section 719-270 are used to determine the start of the test company's loss year based on the identity of the test company and how the loss was made.

---

<sup>1</sup> Subdivision 719-F does not apply if the MEC group has converted to a consolidated group during the ownership test period, where the conversion took place:

- on or after 27 October 2006, or
- before 27 October 2006 and a choice in writing is made within the prescribed time for Subdivision 719-BA to apply from 1 July 2002.

→ section 719-140, ITAA 1997; paragraphs 5.92, 5.105 and 5.106, Explanatory Memorandum to Tax Laws Amendment (2010 Measures No. 1) Bill 2010

## Example

### Facts

SubA makes a tax loss in the income year ended 30 June 2002. On 1 July 2002, a MEC group forms and the loss is transferred to ET2, the head company of the MEC group, as a COT transfer.

ET2, the focal company, seeks to utilise the loss in the income year ended 30 June 2004. ET2 has been the head company at all times since the MEC group formed.

The structure of the group is shown in figure 1.

Figure 1: COT transfer of a loss to the head company of a MEC group

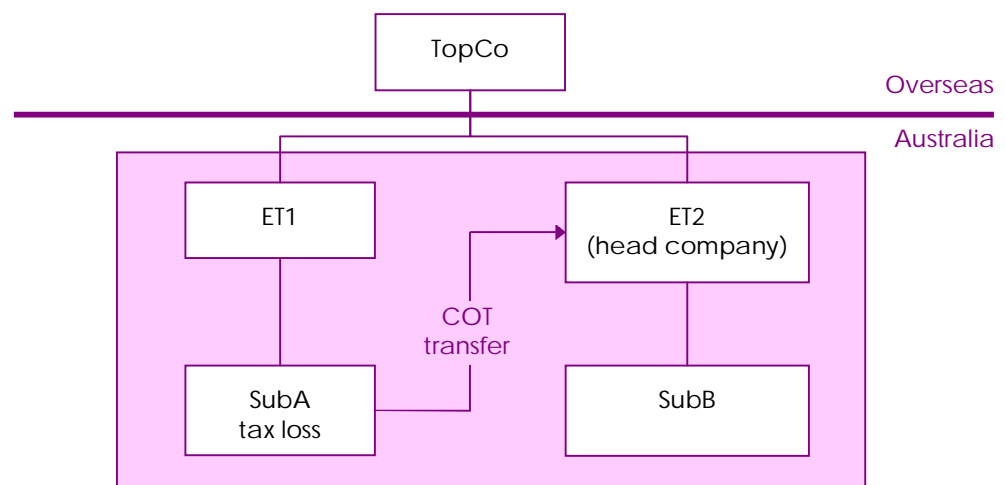

### Calculation

**Under section 719-265, the test company is SubA.** → subsections 719-265(2) (item 2 in the table) and 719-265(4) (item 3 in the table); 'MEC groups and losses – determining whether the focal company satisfies the continuity of ownership test', C10-2-325

Subsection 719-270(1) applies when the test company is also the top company. Subsection 719-270(2) applies when the test company is also the focal company (or the first head company, when the head company has changed and the income tax history of the first head company has been transferred to the new head company under section 719-90).<sup>2</sup>

Because subsections 719-270(1) and (2) do not apply in this case, the table in subsection 719-270(4) does apply.

Item 1 in the table applies because SubA, the test company, is the original maker of the loss. Column 2 of item 1 in the table states that the start of the test company's loss year is the start of the income year in which it made the loss. Therefore, for the purpose of applying the COT, the income year in

<sup>2</sup> Under section 719-90, when the head company of a MEC group is replaced, its income tax history is transferred to the new head company of the group.

---

which SubA (the test company) is assumed to have made the loss starts on 1 July 2001.

## References

*Income Tax Assessment Act 1997*, sections 165-12 and 719-90

Explanatory Memorandum to the New Business Tax System (Consolidation and Other Measures) Bill (No. 1) 2002, paragraphs 3.117 to 3.129

*Income Tax Assessment Act 1997*, Subdivision 719-F, subsection 707-210(1A); as amended by *New Business Tax System (Consolidation and Other Measures) Act 2003* (No. 16 of 2003), Schedule 13

Explanatory Memorandum to the New Business Tax System (Consolidation and Other Measures) Bill (No. 2) 2002, Chapter 3

*Income Tax Assessment Act 1997*, section 719-140; as inserted by *Tax Laws Amendment (2010 Measures No. 1) Act 2010* (No. 56 of 2010), Schedule 5, Part 2

Explanatory Memorandum to Tax Laws Amendment (2010 Measures No. 1) Bill 2010, Chapter 5

### Revision history

Section C10-2-350 first published 28 May 2003.

Further revisions are described below.

Date	Amendment	Reason
6.5.11	Addition of footnote p. 1 to reflect changes to group conversion provisions.	Legislative amendment.