

Worked example

Pre-joining time rollover from foreign-resident company (ACA step 3A)

Description This example explains the adjustment made to the allocable cost amount (ACA) when there is a pre-joining time rollover of a capital loss or gain from a foreign-resident company. This step 3A adjustment is necessary to ensure the rolled over cost base (under Subdivision 126-B of the *Income Tax Assessment Act 1997* (ITAA 1997) or section 160ZZO of the *Income Tax Assessment Act 1936* (ITAA 1936) of the joining entity's assets is reflected in the tax cost setting amounts.

Under Subdivision 126-B or section 160ZZO, the originating company's cost base for the rolled over asset becomes the recipient's cost base. Without adjustment, the tax cost setting process would allocate an amount to the joining entity's assets based on the consideration paid for membership interests in the joining entity, since this reflects the market value of the joining entity's underlying assets. The step 3A adjustment increases or reduces the ACA depending on whether a capital loss or a capital gain has been rolled over.

Note that, after 30 June 2003, a rollover under Subdivision 126-B is only available when:

- an asset is transferred between foreign-resident companies or between a foreign-resident company and an Australian-resident company, and
- the asset has the necessary connection with Australia under section 136-25 of the ITAA 1997.

Commentary **Section 705-93**

When an asset that is not a membership interest is rolled over within a wholly-owned group any gain or loss is deferred. The gain is not taxed until there is a CGT event (without further rollover) and the asset leaves the group – whether because it is disposed of directly or with a leaving entity.

As part of this deferral of tax, the recipient company retains the originating company's cost base for the asset. When the originating company is a foreign resident, this can mean that the group's aggregate cost for its assets is not the same as it would have been if the rollover had not occurred. The purpose of this provision is to offset any such alteration in a group's aggregate cost for its assets.

Step 3A of the ACA applies when:

- a CGT asset is rolled over before the joining time under Subdivision 126-B, or section 160ZZO

- the originating company is a foreign resident and the recipient company is an Australian resident that does not become the head company of the group
- there is no CGT event in relation to the asset (other than another rollover) between the rollover time and the joining time
- the CGT asset is not a pre-CGT asset at the joining time, and
- the entity that was the recipient of the asset, or received the asset as a result of a further rollover, subsequently becomes a member of the group.

When step 3A applies, the ACA for the joining entity is:

- increased by the amount of the capital loss that was disregarded as a result of the rollover (the increase amount), or
- reduced by the amount of the capital gain that was disregarded as a result of the rollover (the reduction amount).

When section 705-93 applies to one or more rollover assets, the ACA is increased or reduced by the net of all reductions and increases. If the ACA – after application of step 3A – is negative, the head company makes a capital gain equal to the negative amount and the ACA for the entity is nil. The CGT event L2 applies to the capital.

Sections that modify section 705-93

Sections 705-147 and 705-227 of the ITAA 1997 ensure that section 705-93 applies correctly when a consolidated group is formed and when linked entities join a consolidated group. These sections modify the operation of section 705-93 to ensure that it applies to the rollover of a membership interest held by a subsidiary entity in another entity that becomes a subsidiary member of the consolidated group at the same time. A membership interest that is a pre-CGT asset is not excluded from the operation of these sections – the pre-CGT status of the membership interest is retained by the pre-CGT factor attached to the underlying assets of the entity.

Sections 705-147 and 705-227 also require that the step 3A adjustment be made to the ACA for the entity that the head company holds direct membership interests in (the first level entity) when that entity holds direct or indirect membership interests in the entity with the rollover asset (the subject entity). For example, when a number of first level entities hold direct or indirect membership interests in the subject entity, the step 3A adjustment is apportioned between the first level entities on the basis of the respective market values of those membership interests. Any remaining amount is allocated to the ACA of the entity holding the rolled over asset.

Section 705-150

Section 705-150 applies when a group forms after the rollover of an asset from the head company to a subsidiary member of the group. The step 3A result is adjusted by section 705-150. CGT event L2 applies if the resultant ACA is negative.

Note

When a non-membership interest asset is rolled over after 16 May 2002, but before a transitional group comes into existence, sections 701-35 and 719-163 of the *Income Tax (Transitional Provisions) Act 1997* may apply.

Example 1 Formation case

In figure 1, the foreign parent (FP) sells a non-membership asset X to BCo and both companies opt for Subdivision 126-B rollover relief on the capital gain. X is not a pre-CGT asset.

When ACo and BCo later consolidate, the calculation of BCo's ACA will require a step 3A adjustment so that the tax deferral amount is appropriately maintained.

Because the asset does not include any membership interests, section 705-93 applies on its own.

Figure 1: Non-membership interest asset rollover to a company that does not become the head company (section 705-93)

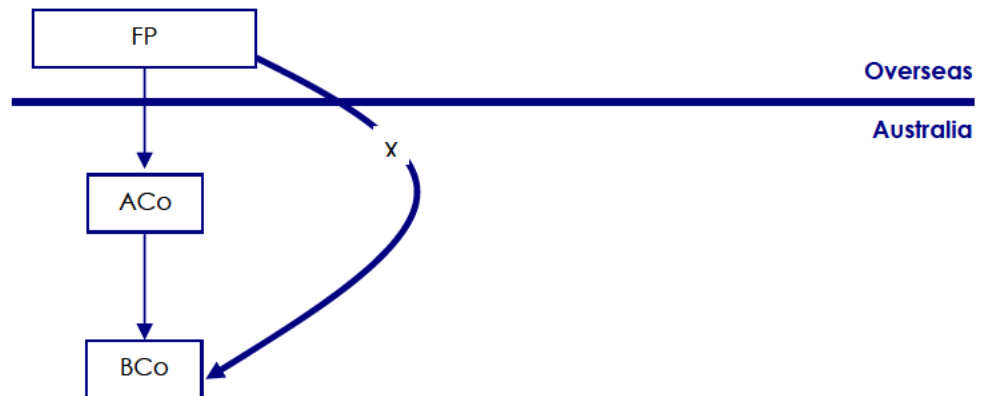

In this example, the sequence of events is:

- FP capitalises ACo with \$200, and ACo uses \$100 to capitalise BCo as its wholly-owned subsidiary.
- FP transfers asset X to BCo. The cost base of X is \$30, and the market value is \$100. FP and BCo elect rollover relief under Subdivision 126-B.
- ACo and BCo form a consolidated group.

The ACA for BCo is calculated as follows:

Step 1: cost base of membership interests in CCo	\$100
Step 3A reduction: (\$100 market value – \$30 cost base)	(\$70)
ACA	\$30

The ACA is then allocated to BCo’s assets as follows:

Tax cost setting amount for asset X	\$30
-------------------------------------	------

Whether asset X is sold by itself or as an asset of a leaving entity, the correct capital gain will now occur.

The step 3A amount is applied at the first level entity in which the head company holds membership interests – an entity that is interposed between the head company and the entity that holds the rollover asset. In this example, there is no interposed entity between the head company and BCo, which holds the rollover asset.

Example 2 Joining case

In figure 2, a non-membership interest asset (X) is sold by FP to CCo and both companies opt for Subdivision 126-B rollover relief on the capital gain. X is not a pre-CGT asset.

Figure 2: Non-membership interest asset rollover before joining time (section 705-93)

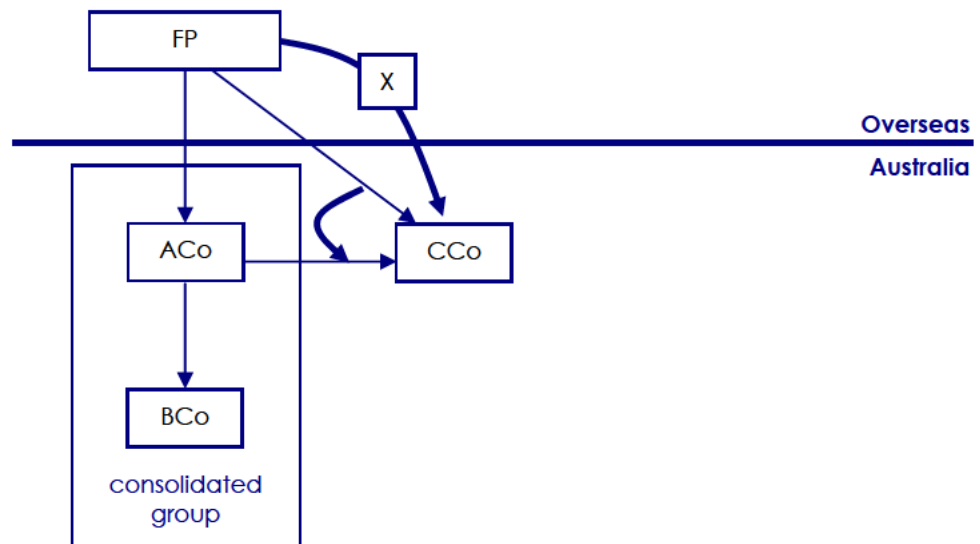

FP later sells its interests in CCo to ACo, the head company of the consolidated group.

When calculating CCo's ACA, step 3A applies to ensure that the tax deferral associated with asset X is appropriately maintained. Because the asset does not include any membership interests, section 705-93 applies on its own.

Note that there is not another step 3A adjustment if Subdivision 126-B rollover is elected for the second transfer, as that rollover is to a head company.

In this example, the sequence of events is:

- FP capitalises two Australian-resident companies – ACo with \$200, and CCo with \$100.
- ACo in turn capitalises a wholly-owned subsidiary, BCo, with \$100 and they form a consolidated group.
- CCo purchases asset X from FP for the asset's market value of \$100. FP's cost base for asset X is \$30, and FP and CCo both opt for Subdivision 126-B rollover relief.
- FP sells all its membership interests in CCo to ACo for \$100. CCo becomes a member of the consolidated group and asset X becomes an asset of ACo under the single entity rule in subsection 701-1(1).

The ACA for CCo is calculated as follows:

Step 1: cost base of membership interests in CCo	\$100
Step 3A: reduction amount	(\$70)
ACA	\$30

The ACA is then allocated to CCo's assets as follows:

Tax cost setting amount for asset X	\$30
-------------------------------------	------

Whether asset X is sold by itself, or as an asset of a leaving entity, the correct capital gain will now occur.

The step 3A amount is applied at the first level entity in which the head company holds membership interests – an entity that is interposed between the head company and the entity that holds the rollover asset. In this example, there is no interposed entity between the head company and CCo, which holds the rollover asset.

Example 3 Allocation of step 3A amount after rollover of asset X

In figure 3, FP sells its non-membership asset, X, to JCo and both companies opt for Subdivision 126-B rollover relief. X is not a pre-CGT asset.

When GCo, HCo, ICo and JCo consolidate, the ACA calculation requires a step 3A adjustment so that the tax deferral amount is appropriately maintained.

Although the head company, GCo, has a direct interest in JCo (the company owning the rollover asset), there are also companies interposed between them.

This means section 705-147 applies to modify section 705-93 and apportion the step 3A amount.

The apportionment between the first level entities (HCo and ICo) is made using the market value of their respective direct and indirect membership interests in JCo as a proportion of the total value of the membership interests in JCo. The balance of the step 3A amount is allocated to JCo's ACA.

Figure 3: Non-membership interest asset with multiple interposed companies (section 705-147)

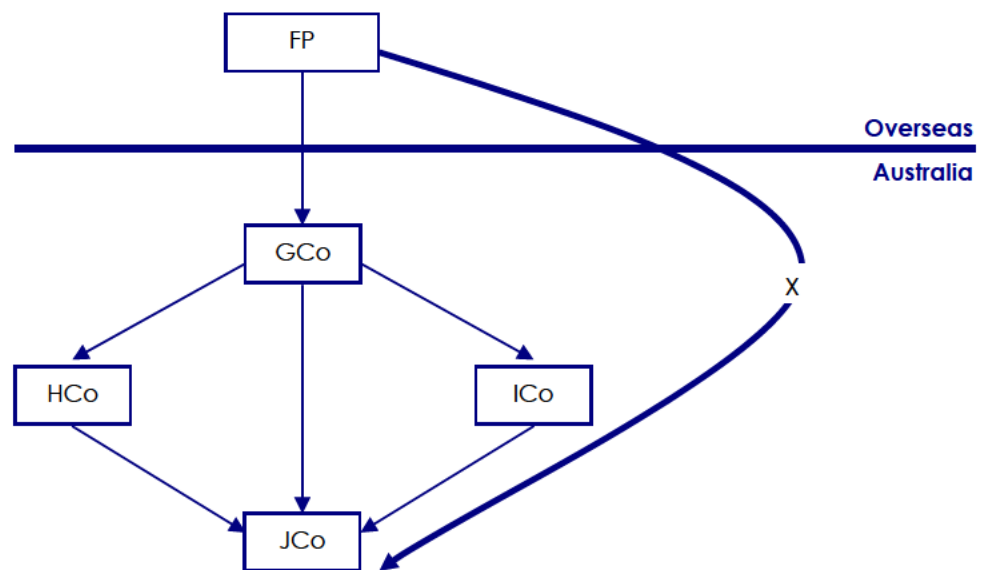

In this example, the sequence of events is:

- FP capitalises GCo with \$200, and GCo capitalises two wholly-owned subsidiaries, HCo and ICo, with \$40 each.
- GCo (\$20), HCo (\$40) and ICo (\$40) capitalise JCo with \$100.
- JCo purchases asset X from FP for its market value of \$100. FP's cost base for asset X is \$30. FP and JCo opt for Subdivision 126-B rollover relief.
- GCo, HCo, ICo and JCo form a consolidated group with GCo as the head company.

The ACA for membership interests in JCo is calculated as follows:

HCo's membership interests in JCo

Step 1: cost base of membership interests	\$40
Step 3A:	
\$70 capital gain x $\frac{\text{market value of HCo's membership interests in JCo}}{\text{market value of all membership interests in JCo}}$	$= \frac{70 \times 40}{100} = (\$28)$
ACA	\$12

The ACA is allocated as follows:

Tax cost setting amount for HCo's membership interests in JCo	\$12
---	------

ICo's membership interests in JCo

Step 1: cost base of membership interests	\$40
Step 3A:	
\$70 capital gain x $\frac{\text{market value of ICo's membership interests in JCo}}{\text{market value of all membership interests in JCo}}$	$= \frac{70 \times 40}{100} = (\$28)$
ACA	\$12

The ACA is allocated as follows:

Tax cost setting amount for ICo's membership interests in JCo	\$12
---	------

JCo's ACA

Step 1: cost base of all membership interests in JCo (held by GCo, HCo and ICo = 20 + 12 + 12)	\$44
Step 3A: the balance	(\$14)
ACA	\$30

The ACA is allocated as follows:

Tax cost setting amount for asset X	\$30
-------------------------------------	------

The step 3A adjustment is made in working out the ACA for HCo and ICo – the first level entities below the head company. Any balance is allocated to JCo.

Section 705-140, contained in Subdivision 705-B, provides that Subdivision 705-A (which contains section 705-93) applies to each entity becoming a member of a consolidated group in the same way as Subdivision 705-A applies to an entity becoming a subsidiary member of a consolidated group in circumstances covered by Subdivision 705-A. Section 705-147 modifies the application of section 705-93 to ensure that it applies when the rolled over asset is a membership interest in an entity that becomes a subsidiary member of the group at formation time.

Example 4 Allocation of step 3A amount after rollover of membership interests in CCo

This example differs from example 3 in that the rollover assets are 100% of the membership interests in a group company.

In figure 4, FP sells all its membership interests in CCo to JCo and both companies opt for Subdivision 126-B rollover relief.

When GCo, HCo, ICo, JCo and CCo consolidate, the ACA calculation requires a step 3A adjustment to ensure that the tax deferral amount is appropriately maintained.

The rollover assets are membership interests. The head company, GCo has a direct interest in JCo (which owns the rollover asset), but there are also companies interposed between the two companies. Section 705-147 applies to modify section 705-93 and apportion the step 3A amount.

The apportionment between the first level entities (HCo and ICo) is made using the market value of their respective direct and indirect membership interests in JCo as a proportion of the total value of the membership interests in JCo. Any balance of the step 3A amount is attributed to JCo's ACA.

Figure 4: Membership interest asset when there are multiple interposed companies (section 705-147)

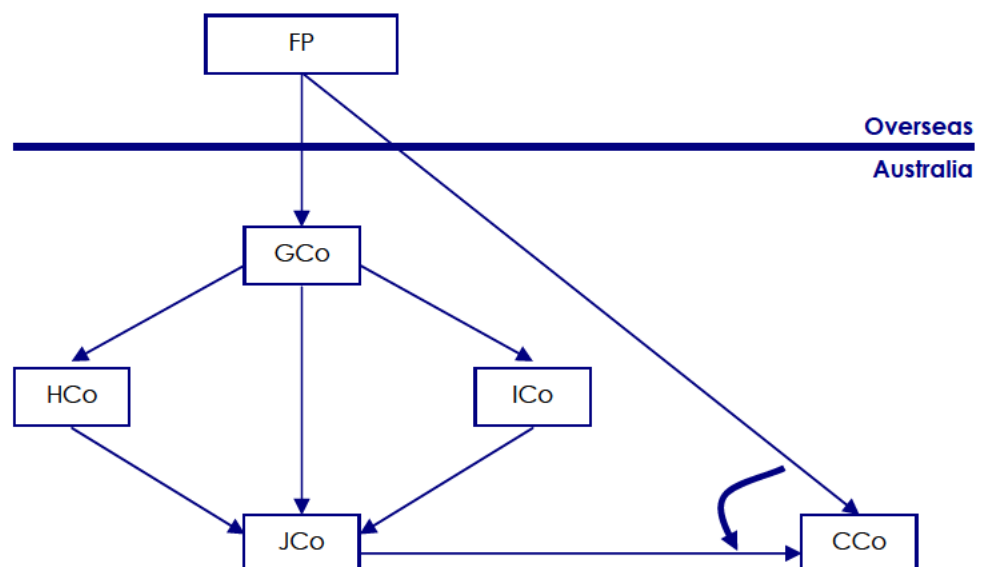

The outcome is similar to the previous example except that the ACA is apportioned by the market value over all assets in JCo – including the membership interests in CCo (whereas in example 3, the only asset of JCo was asset X.).

Example 5 Allocation of step 3A amount and linked entities

In figure 5, FP sells all its membership interests in FCo to DCo and both elect Subdivision 126-B rollover relief.

FP later sells all its membership interests in CCo to ACo, which means the linked entities – CCo, DCo and FCo – all join the consolidated group headed by ACo. The rollover of the membership interests in FCo requires a step 3A adjustment in the ACA calculation.

Figure 5: Membership interest asset and linked entities (section 705-227)

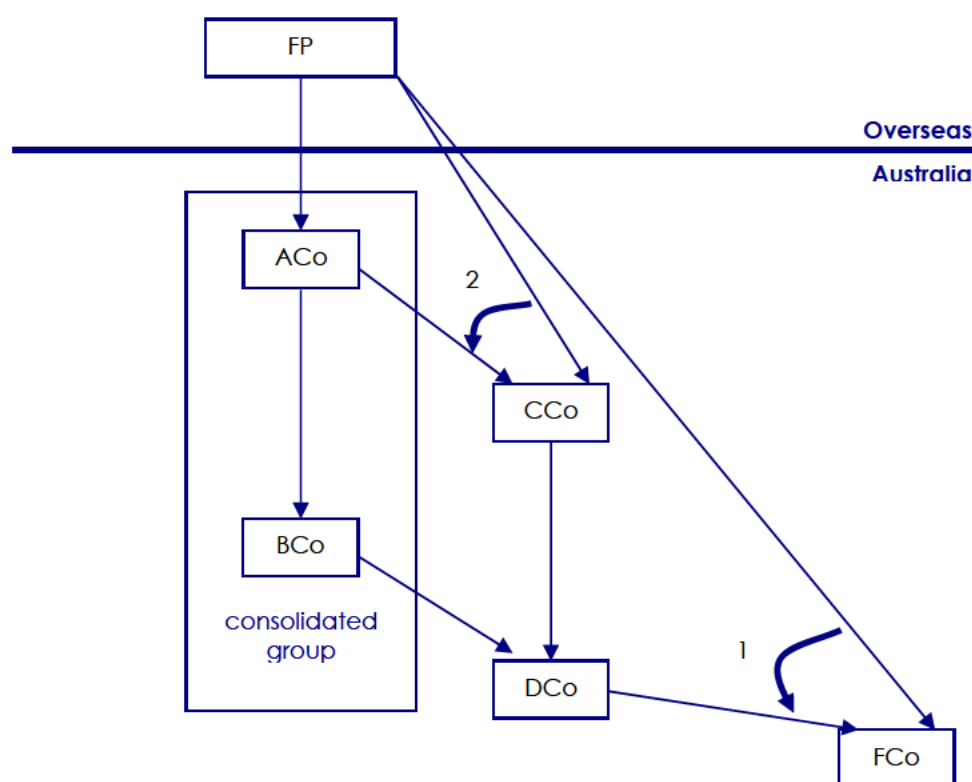

Section 705-227 modifies section 705-93 to take account of the membership interests that one linked entity holds in another. In this example, the rollover assets (all the membership interests in FCo) are held by DCo. DCo, FCo, and CCo are linked entities that join the consolidated group as a result of the second transaction.

The step 3A amount is apportioned between any first level entities (in this case, CCo) based on the market value of its direct and indirect membership interests in DCo as a proportion of the total value of the membership interests in DCo.

Any balance of the step 3A amount is allocated to DCo's ACA.

Example 6

In figure 6, foreign parent TC first sells its interests in CCo to BCo, then sells its interests in BCo to ACo – on both occasions, the parties to the transaction opt for Subdivision 126-B rollover relief.

Figure 6: Eligible tier-1 companies of a MEC group are rolled under to form a consolidatable group (section 705-147)

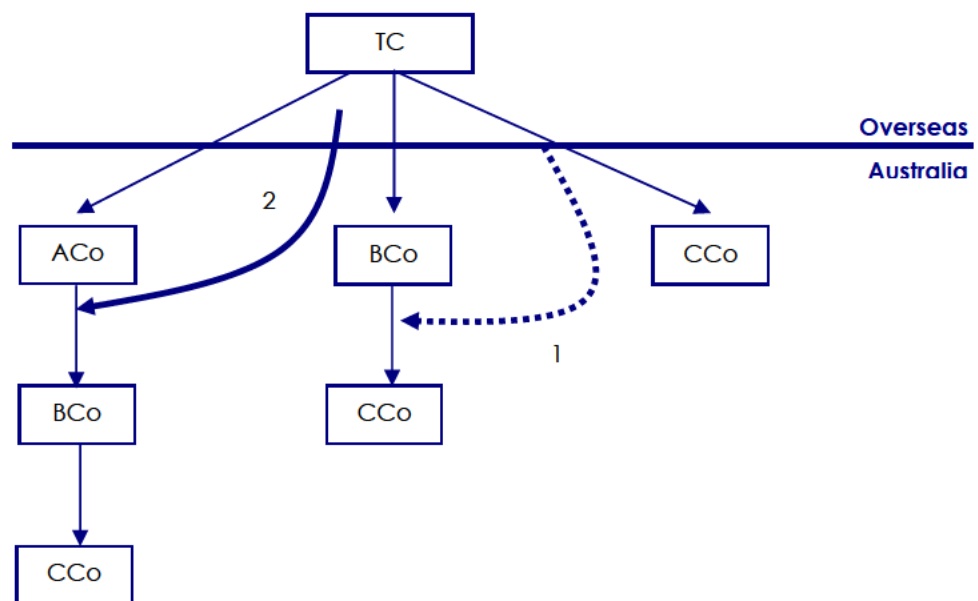

When ACo, BCo and CCo consolidate, section 705-147 applies – a step 3A amount with respect to the first rollover is applicable in calculating BCo's ACA.

Example 7 Figure 7 shows one consolidated group taking over another consolidated group. Step 3A applies if there is a Subdivision 126-B rollover from non-resident TC to the consolidated group of ECo and FCo.

Figure 7: Membership interests and consolidated group (section 705-93)

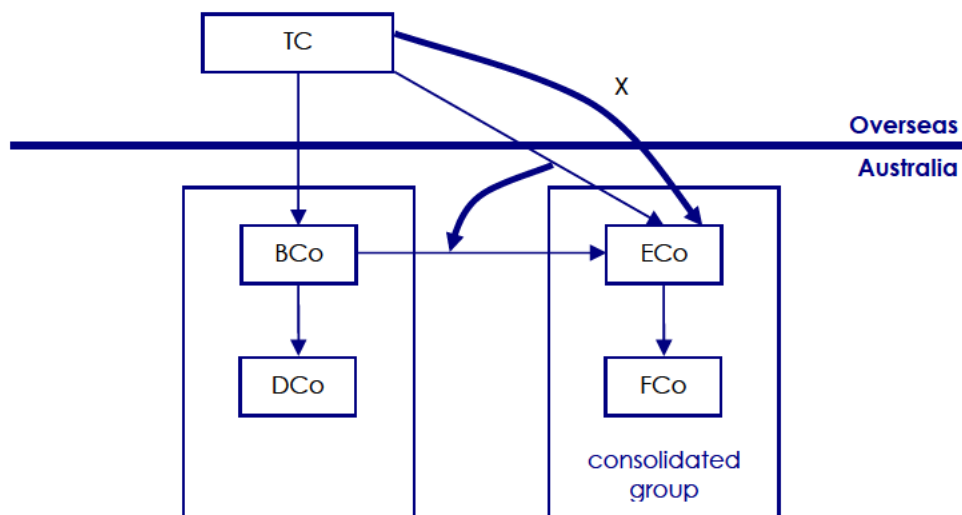

Example 8 The MEC group in figure 8 can choose to include ECo and FCo, but step 3A does not apply. Subdivision 126-B rollovers from non-resident RCo to ECo or FCo take place when ECo and FCo consolidate. ECo and FCo's assets do not need to be reset.

Figure 8: No step 3A – if TC acquires the remaining interests in RCo

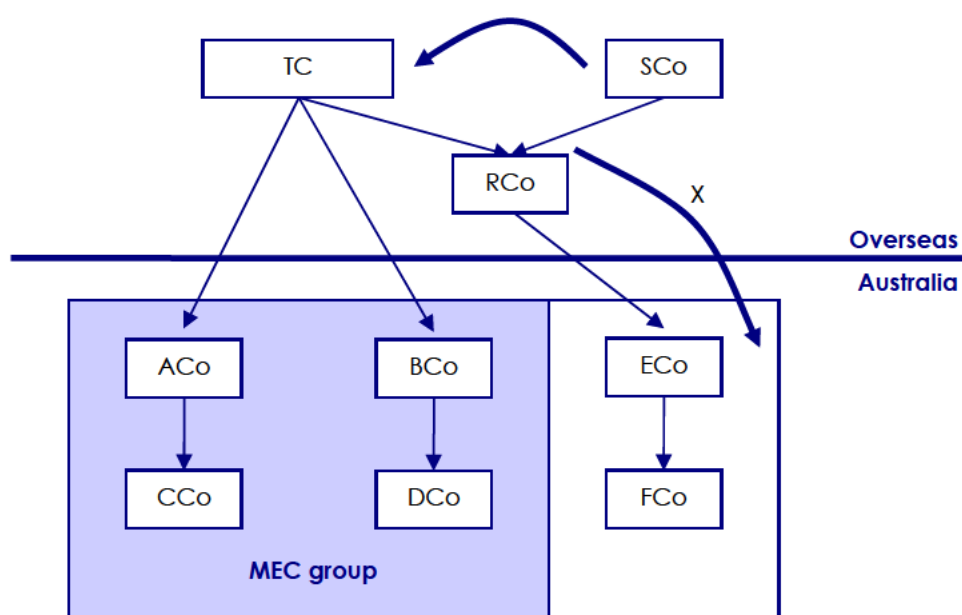

References *Income Tax Assessment Act 1936*, section 160ZZO

Income Tax Assessment Act 1997, Subdivision 126-B and section 136-25

Income Tax Assessment Act 1997, subsection 701-1(1), Subdivision 705-A and Subdivision 705-B; as amended by *New Business Tax System (Consolidation and Other Measures) Act 2003* (No. 16 of 2003), Schedule 1

Income Tax (Transitional Provisions) Act 1997, section 701-35; as amended by *New Business Tax System (Consolidated, Value Shifting, Demergers and Other Measures) Act 2002*, Schedule 7

Income Tax (Transitional Provisions) Act 1997, sections 701-35 and 719-163; as amended by *New Business Tax System (Consolidation and Other Measures) Act 2003* (No. 16 of 2003), Schedule 17

Explanatory Memorandum to New Business Tax System (Consolidated, Value Shifting, Demergers and Other Measures) Bill 2002, paragraphs 1.104 to 1.107

Explanatory Memorandum to New Business Tax System (Consolidation and Other Measures) Bill (No. 2) 2002, paragraphs 5.75 to 5.88 and 5.45 to 5.52