

Worked example

Modified cost setting rules for consolidated groups that include a life insurance company

Description When an entity joins a consolidated group, or a consolidated group is formed, the tax costs of the assets of each joining entity are aligned with the cost to the group of acquiring the entity (unless the head company chooses the transitional option of retaining existing tax values). The cost setting rules are used to obtain the tax cost of each asset → 'Treatment of assets', C2-1. The group's cost for each asset is worked out by allocating the ACA (allocable cost amount) for the joining entity among the entity's assets. This example shows how the cost setting rules are modified when a life insurance company joins a consolidated group.

Commentary Subdivision 713-L of the *Income Tax Assessment Act 1997* (ITAA 1997) modifies the tax cost setting rules in Subdivision 705-A to specify:

- which assets of life insurance companies are to be treated as retained cost base assets (see table 1), and
- the basis of valuing life insurance policy liabilities for the purposes of working out the ACA (see table 2).

Table 1: Retained cost base assets of a life insurance company

Basic principle in Subdivision 705-A	Modification in Subdivision 713-L	Tax cost setting amount specified as...
Retained cost base assets are defined in subsection 705-25(5)	Assets of a life insurance company defined as retained cost base assets are:	
	(a) a virtual PST asset or a segregated exempt asset	The transfer value* just before the joining time**, for the purpose of working out the tax cost setting amounts for reset cost base assets (→ section 705-35), or
	(b) certain assets held for the purpose of discharging liabilities under the net investment component of ordinary life insurance policies, and	for all other purposes, the assets' terminating value (→ section 705-30))
	(c) in certain circumstances, the goodwill asset of a life insurance company that has demutualised	The embedded value (under section 121AM of the ITAA 1936) of the life insurance company reduced by the net value of shareholders' assets held by the company.

* The transfer value of an asset is the amount expected to be received from disposal of the asset in an open market after deducting any expected costs in relation to that disposal.

** When a life insurance company joins a consolidated group, the joining time is taken to be a valuation time for the purposes of Division 320. Life insurance companies therefore need to value both virtual PST assets and segregated exempt assets, and their associated liabilities, immediately before they join a group. This ensures the transfer value of the assets is aligned with the value of the relevant liabilities.

Table 2: Modifications to step 2 of the ACA for a life insurance company

Basic principle in Subdivision 705-A	Modification in Subdivision 713-L	Value prescribed as...
In step 2 of the ACA, liabilities are valued in accordance with accounting standards, or with statements of accounting concepts made by the AASB → subsection 705-70(1)	The following liabilities have a prescribed value:	
	(a) virtual PST liabilities	The amount worked out under section 320-190 at the joining time*
	(b) exempt life insurance policy liabilities	The amount worked out under section 320-245 at the joining time*
	(c) liabilities under net risk components of life insurance policies	The current termination value of that component at the joining time as calculated by an actuary
	(d) liabilities under net investment components of ordinary life insurance policies	The amount worked out for those liabilities under subsection 320-190(2) as if those liabilities were virtual PST liabilities

* When a life insurance company joins a consolidated group, the joining time is taken to be a valuation time for the purposes of Division 320. Life insurance companies therefore need to value both virtual PST assets and segregated exempt assets, and their associated liabilities, immediately before they join a group. This ensures the transfer value of the assets does not exceed the value of the relevant liabilities.

Example

Facts HeadCo, whose income year ends on 30 June, chooses to consolidate with effect from 1 July 2002. Assuming the modified membership rules are satisfied, the consolidated group is structured as shown in figure 1.

Figure 1: Structure of the consolidated group

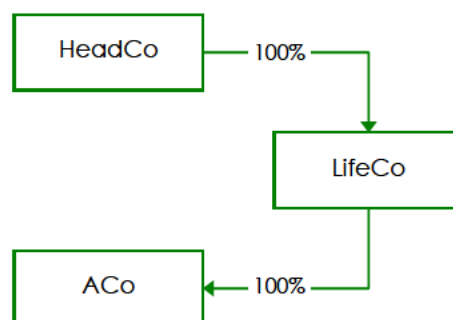

Table 3: LifeCo's financial position at 30 June 2002 (\$)

Building	1,000	Capital	1,400
Shares in ACo	300	Retained profits	70
Shares in YCo	200	Liabilities	
Units in Alpha Trust	500	- Loan*	500
Cash	950	- Policy liabilities**	950
		- Income tax	30
	<u>2,950</u>		<u>2,950</u>

* Not an intragroup loan.

** All policy liabilities relate to complying superannuation business and immediate annuity business.

Note: LifeCo uses market value accounting for its investments.

The following assets are segregated for the purposes of Division 320:

- all shares in ACo – virtual PST assets
- cash includes \$150 – virtual PST assets and \$100 – segregated exempt assets, and
- all units in Alpha Trust – segregated exempt assets.

Table 4: ACo's financial position at 30 June 2002 (\$)

Cash	50	Capital	300
Property	100		
Shares in ZCo	150		
	<u>300</u>		<u>300</u>

Application of cost setting rules

When a consolidated group is formed, no changes are made in relation to the assets of the head company (except that intragroup membership interests and debts are ignored after formation). The cost setting rules establish the tax values of assets owned by the subsidiary companies.

HeadCo must first apply the cost setting rules to LifeCo before it applies them to ACo. → section 705-145

In accordance with section 713-525, LifeCo undertakes a valuation under section 320-175 (for its virtual PST assets) and section 320-230 (for its segregated exempt assets) and carries out any resulting transfers under sections 320-180 and 320-235.

The transfer values of LifeCo's virtual PST assets and segregated exempt assets immediately before joining the consolidated group are set out in table 5. The table also sets out the value of LifeCo's virtual PST liabilities and exempt life insurance liabilities at the joining time.

Table 5: Modified values of segregated assets and liabilities of LifeCo (\$)

	Division 320 value
Assets	
Cash (virtual PST asset)	150
Shares in ACo (virtual PST asset)	300
Cash (segregated exempt asset)	100
Units in Alpha Trust (segregated exempt asset)	500
Liabilities	
Virtual PST liabilities	450
Exempt life insurance liabilities	500

As a consequence of these valuations, LifeCo must transfer the excess segregated exempt assets (\$100) out of the segregated exempt asset pool within 30 days of the date of valuation → section 320-235.

Assume LifeCo transfers \$100 cash from its segregated exempt assets.

Setting tax costs of LifeCo's assets

1. Calculate LifeCo's entry ACA

ACA step 1:	The cost base of membership interests*	\$1,400
ACA step 2:	Value of LifeCo's liabilities	
	– loan	\$500
	– income tax	\$30
	– virtual PST liabilities	\$450
	– exempt life insurance liabilities	\$500
		\$1,480
ACA step 3:	Undistributed frankable profits**	\$70
LifeCo's entry ACA (assuming no other adjustments are required)		\$2,950

* Assume the market value of membership interests equals the cost base of those interests.

** Assume the retained earnings are undistributable frankable profits under section 705-90.

2. Determine ACA to be allocated to LifeCo's reset cost base assets

Total entry ACA for LifeCo	\$2,950	
Less amounts for retained cost base assets of LifeCo		
	– cash (including virtual PST cash of \$150 and \$100 cash transferred from segregated exempt assets)	\$950
	– shares in ACo	\$300
	– units in Alpha Trust	\$500
		\$1,750
Remaining ACA	\$1,200	

Note: For the purpose of working out the tax cost setting amount for reset cost base assets under section 705-35, the transfer values of the shares in ACo and the units in Alpha Trust are used. However, for all other purposes the 'terminating value' under section 705-30 is used → subsection 713-515(2).

3. Allocate remaining ACA to LifeCo's reset cost base assets

Asset	Market value (\$)	Apportionment of remainder of entry ACA	Cost setting amount (\$)
Building	1,000	$1000/1200 \times 1200$	1000
Shares in YCo	200	$200/1200 \times 1200$	200
Total	1,200		1,200

Setting tax costs of ACo's assets

1. Calculate ACo's entry ACA

ACA step 1: The cost base of membership interests*	\$300
ACo's entry ACA (assuming no other adjustments are required)	\$300

* Generally, the tax cost setting amount calculated for the membership interest in a subsidiary is used as the ACA step 1 amount in order to calculate the tax cost setting amounts for assets of the subsidiary → subsection 705-145(3).

The tax cost setting amount for shares in ACo outlined on p. 4 under '2. Determine ACA to be allocated to LifeCo's reset cost base assets' is \$300 only for the purposes of working out the tax cost setting amount for reset cost base purposes → section 705-35.

Shares in ACo are a virtual PST asset of LifeCo. In this situation, the tax cost setting amount is the asset's terminating value → paragraph 713-515(2)(b). Therefore, the step 1 amount of ACo's entry ACA is the terminating value of the virtual PST asset (i.e. the membership interest LifeCo holds in ACo).

In this example, the terminating value is the same as the amount used in determining the ACA to be allocated to LifeCo's reset cost base assets. For all other purposes, the tax cost setting amount is the asset's terminating value.

2. Determine ACA to be allocated to ACo's reset cost base assets

Total entry ACA for ACo	\$300
Less amounts for retained cost base assets of ACo	
– cash	\$50
Remaining ACA	\$250

3. Allocate remaining ACA to ACo's reset cost base assets

Asset	Market value (\$)	Apportionment of remainder of entry ACA	Cost setting amount (\$)
Property	150	$150/250 \times 250$	150
Shares in ZCo	100	$100/250 \times 250$	100
Total	250		250

References

Income Tax Assessment Act 1936, section 121AM

Income Tax Assessment Act 1997, sections 705-30, 705-35, 705-70, 705-90 and subsection 705-25(5); as amended by *New Business Tax System (Consolidation) Act (No. 1) 2002* (No. 68 of 2002), Schedule 1

Income Tax Assessment Act 1997, section 705-145; as amended by *New Business Tax System (Consolidation, Value Shifting, Demergers and Other Measures) Act (No. 90 of 2002)*, Schedule 3

Income Tax Assessment Act 1997, Subdivision 713-L; as amended by *New Business Tax System (Consolidation and Other Measures) Act (No. 2) 2002*, Schedule 6, Part 1

Explanatory Memorandum to the New Business Tax System (Consolidation and Other Measures) Bill (No. 2) 2002, Chapter 1

Revision history

Section C9-6-520 first published 28 May 2003.

Further revisions are described below.

Date	Amendment	Reason
27.10.03	Table 2 (Modifications to step 2 of the ACA for a life insurance company) amended to include exempt life insurance policy liabilities.	Technical correction
	Table 3 amended to change the composition of assets segregated for the purposes of Division 320.	Technical correction